



**Vertical Wall Mount Brackets**



**Description**

Vertical Wall Mount Brackets allow servers and other networking equipment to mount vertically and flush to a wall, providing a cost-effective mounting solution for environments with limited space. These RoHS Compliant brackets feature universal cage hole mounting and an opening in the rear panel for in-wall cable access. These brackets have the versatility to support a wide variety of equipment regardless of depth.

**Product Specifications**

- Product Type:** Wall Mount Bracket
- Material:** 14 Gauge Cold Rolled Steel
- Finish:** Black Powder Coated
- Loading Capacity:** 75 Lbs.
- Dimensions (HxWxD):** Varies By Item #
- Unit Weight:** Varies By Item #
- Rack Unit Quantity:** 2U, 4U or 6U
- Hardware:** 10 pcs M6 Cage Nuts And Screws Included
- Compliance & Standards:** RoHS, ANSI / EIA RS-310D, IEC60297-2, DIN41494; Part 1, DIN41494; Part 7
- Quantity Per Package:** Sold Individually
- Carton Dimensions (HxWxD):** Varies By Item #
- Carton Weight:** Varies By Item #

**Ordering Information**

Description						
Vertical Wall Mount Bracket						
Item #	Rack Units	Loading Capacity	Unit Dims (HxWxD)	Unit Weight	Carton Dims (HxWxD)	Carton Weight
VB2-021	2U	75 Lbs.	7.80" X 19.23" X 4.20"	4.60 Lbs.	20.25" X 9.5" X 3"	5.35 Lbs.
VB2-041	4U	75 Lbs.	7.80" X 19.23" X 7.70"	5.90 Lbs.	20.25" X 9.5" X 3"	6.75 Lbs.
VB2-061	6U	75 Lbs.	7.80" X 19.23" X 11.20"	9.65 Lbs.	20.25" X 13" X 3"	10.70 Lbs.



Vertical Wall Mount Brackets

Technical Drawing: 2U

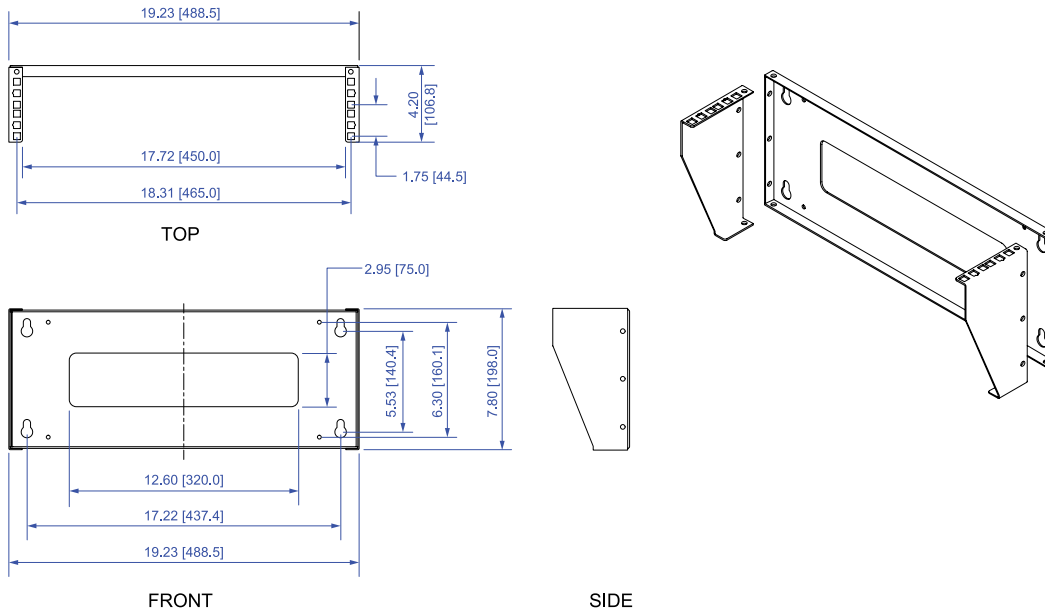

Technical Drawing: 4U

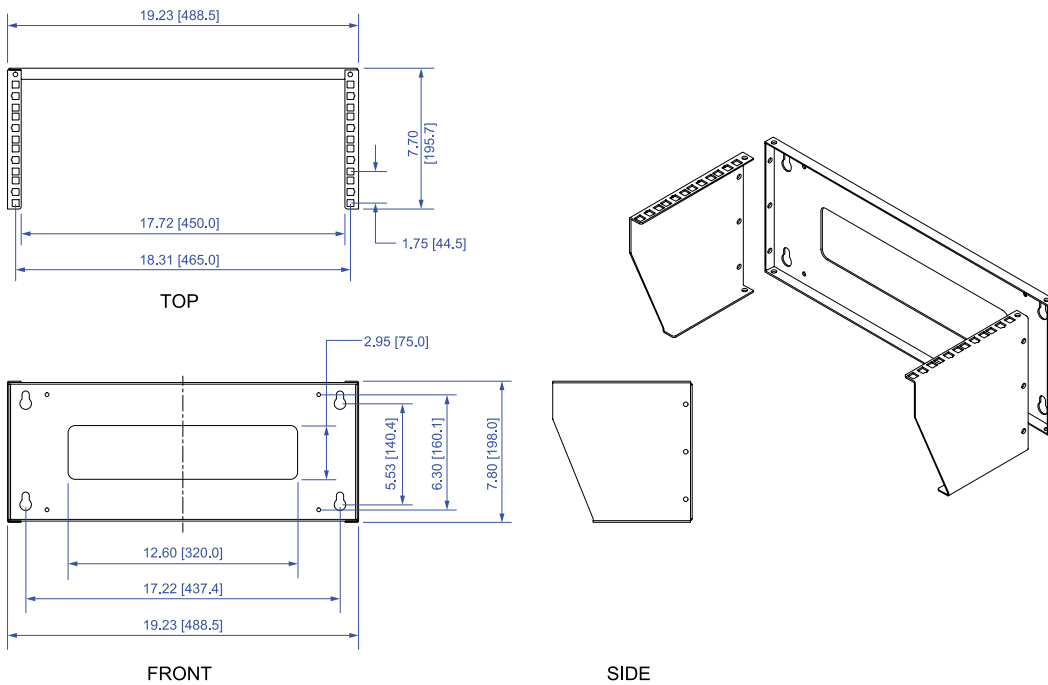

TECHNICAL SHEETS ARE SUBJECT TO CHANGE WITHOUT NOTICE.

REV.20250109.3

**Vertical Wall Mount Brackets**

**Technical Drawing: 6U**

