



Top Mount Quad Fan, 300 CFM



Description

The Top Mount Quad Fan can be added to any Vericom Network, Server, or SOHO cabinet to provide the additional airflow required to keep equipment running cool. Powerful yet quiet, this fan is a great option for installations in any environment.

Technical Drawing

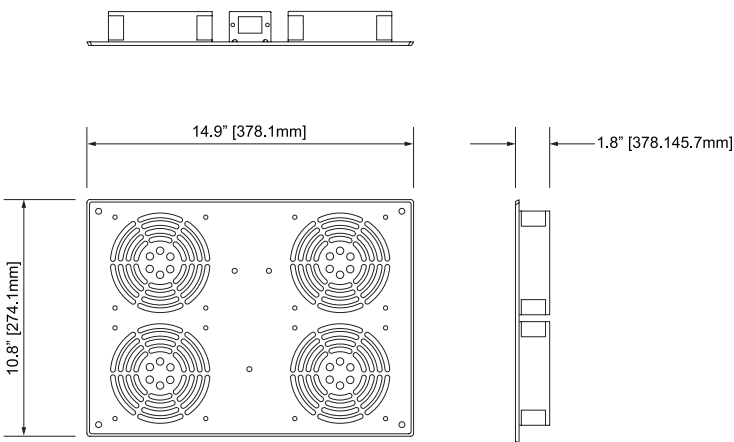

Product Specifications

- Product Type:** Electric Fan
- Impeller Material:** PBT Reinforced Plastic
- Terminals:** 0.02"
- Dimensions (HxWxD):** 1.9" x 14.9" x 10.8"
- Motor:** Shaded Pole Induction Motor
- Bearing System:** Sleeve
- Cord Length:** 6 ft (*Detachable*)
- Operating Temperature:** -10°C ~ 70°C
- Voltage:** Varies By Item #
- Frequency:** 50 / 60 Hz
- Current:** 0.96 Amps
- Power:** 10 / 9 Watts
- Speed:** 2100 / 2400 RPM
- Noise:** 160 dBA
- Airflow:** 300 CFM
- Static Pressure:** 3.1 / 4.1 (mmH²O)
- Weight:** 6.50 lbs
- Quantity Per Package:** 1

Ordering Information

Description	
Top Mount Quad Fan, 300 CFM	
Item #	Voltage
RAFNQ04	110V
RAFNQ04-C14	220V